

COMBi-PPT

8,000 kg

HIGH CAPACITY
POWERED PALLET TRUCK

COMBiLiFT

LIFTING INNOVATION

Equipped with our patented multi-position tiller arm the Combi-PPT offers safer operation, maximum operator visibility and narrow aisle performance.

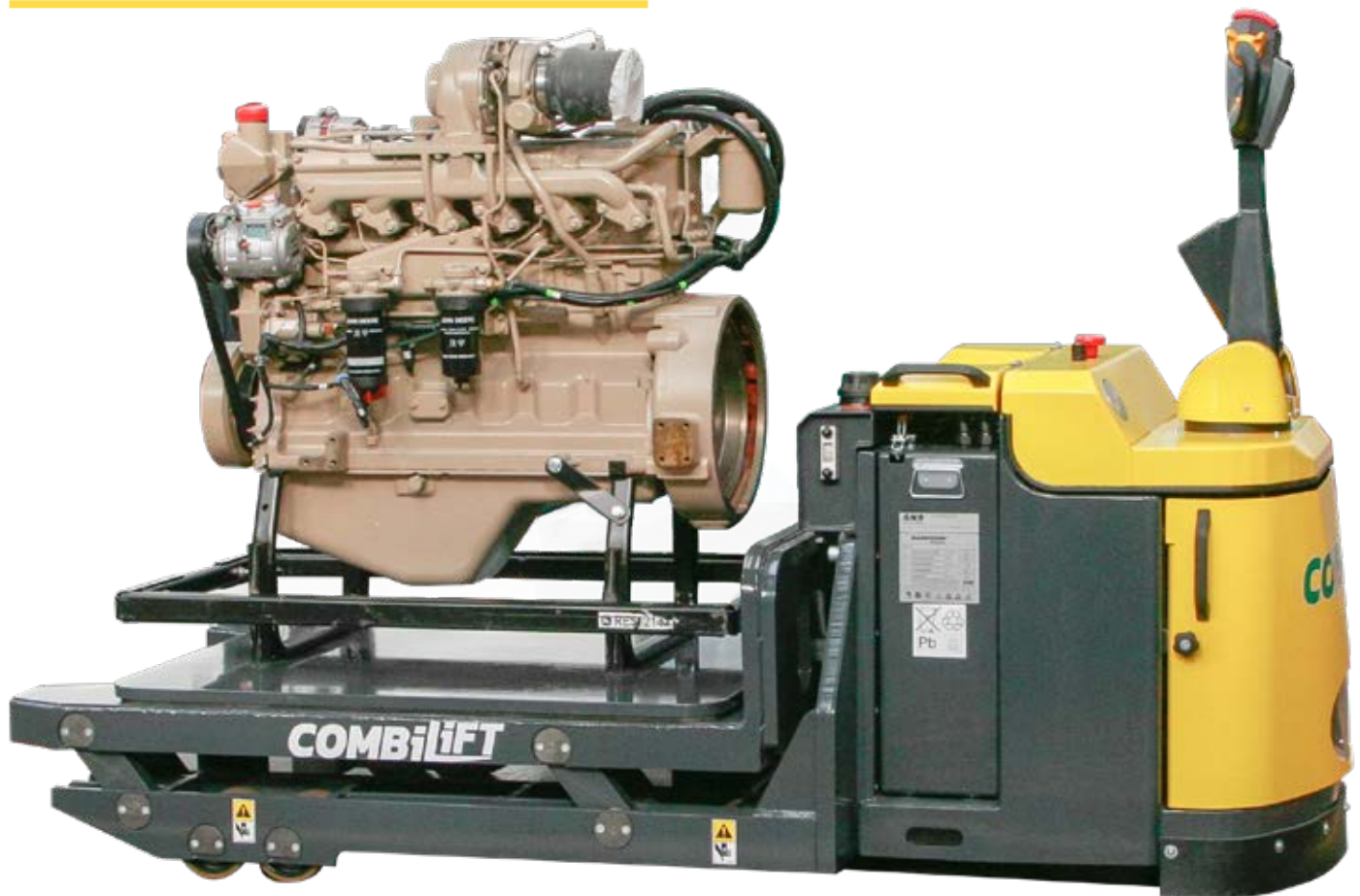

9,000 kg - 16,000 kg available on request



combilift.com

COMBi-PPT

8,000 kg

HIGH CAPACITY POWERED PALLET TRUCK

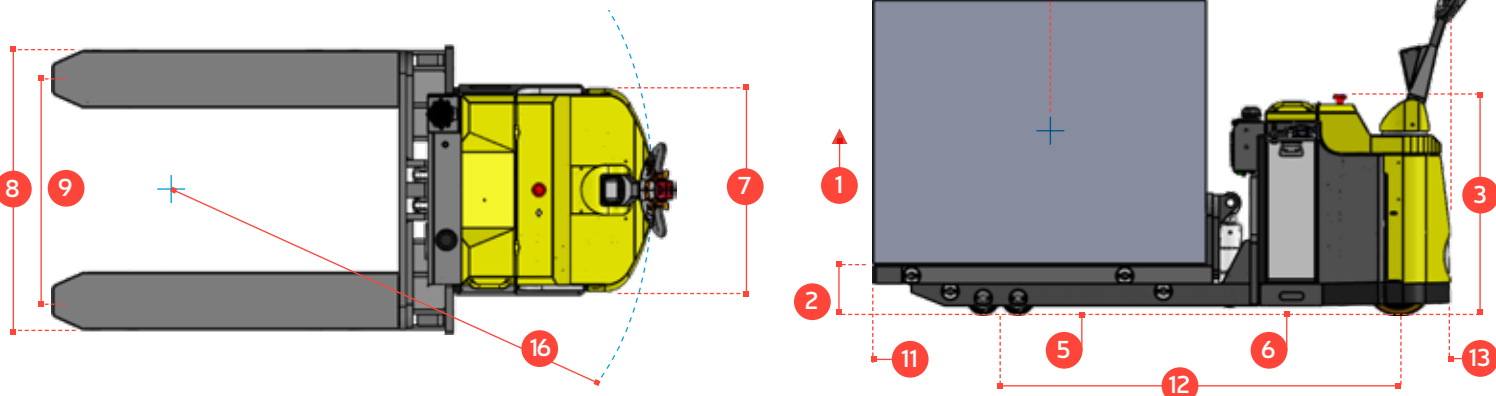

REF.	DESCRIPTION	STANDARD
1	Max. Lift Height	90 mm
2	Lowered Height	230 mm
3	Overall Height	1050 mm
4	Overall Length	3278 mm
5	Ground Clearance Under Fork	20 mm
6	Ground Clearance to Centre of Wheelbase	20 mm
7	Width	920 mm
8	Outside Spread of Fork Arms	1220 mm (other sizes available)
9	Track Front	1940 mm
10	Load Centre Distance	600 mm
11	Overhang Front	1006 mm
12	Wheelbase	3657 mm
13	Overhang Back	220 mm
14	Length From Face of Fork	2230 mm
15	Fork Length	1524 mm (other sizes available)
16	Minimum Outside Radius	4112 mm
A	Capacity	8000 kg
B	Maximum Ground Speed	6 km/h
C	Gradeability	5%
D	Battery Capacity	24 V / 375 Ah
F	Front Tyre (Polyurethane) x 8	OD 150 mm / Width 95 mm
G	Rear Tyre (Vulkollan) x 2	OD 313 mm / Width 125 mm
H	Standard Colour	Yellow & Grey
I	AC Electric Traction Motor x 2	24 V / 4 kW
J	AC Electric Pump Motor	24 V / 5 kW
K	Unladen Weight	2,550 Kg

European Patent No.2891841

Without Combi-PPT

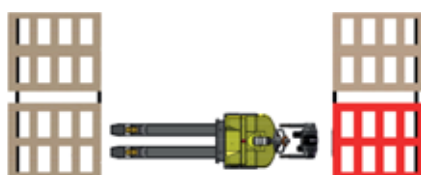

Using Combi-PPT



Standing to the side of the truck eliminates the risk of being trapped or crushed while allowing the Combi - PPT to operate in very narrow aisles.

Superior safety with Combilift's patented Multi-Position Tiller Arm

The tiller can be turned to the left or right to allow the operator to remain at the side. This enables full visibility of the load and forks, while maintaining full steering control, providing greater awareness of the surroundings for enhanced overall safety.

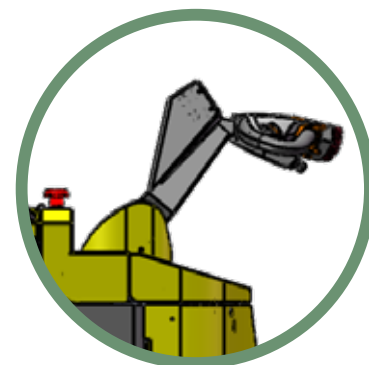

Features Include:

- Power Steering
- AC Motor Technology
- Dual Rear Wheel Drive
- Patented Multi-Position Tiller Arm

Optional Extras:

- Alternative Fork Configurations
- Camera
- Auxiliary Hydraulics
- Ride-on Platform

COMBILIFT HAS A POLICY OF CONTINUOUS PRODUCT DEVELOPMENT AND RESERVES THE RIGHT TO ALTER SPECIFICATIONS WITHOUT PRIOR NOTICE. SPECIFICATIONS AND/OR DIMENSIONS MAY VARY FROM THOSE ILLUSTRATED IN SOME COUNTRIES.